

J. HARLEY.
LATHE.

No. 436,175.

Patented Sept. 9, 1890.

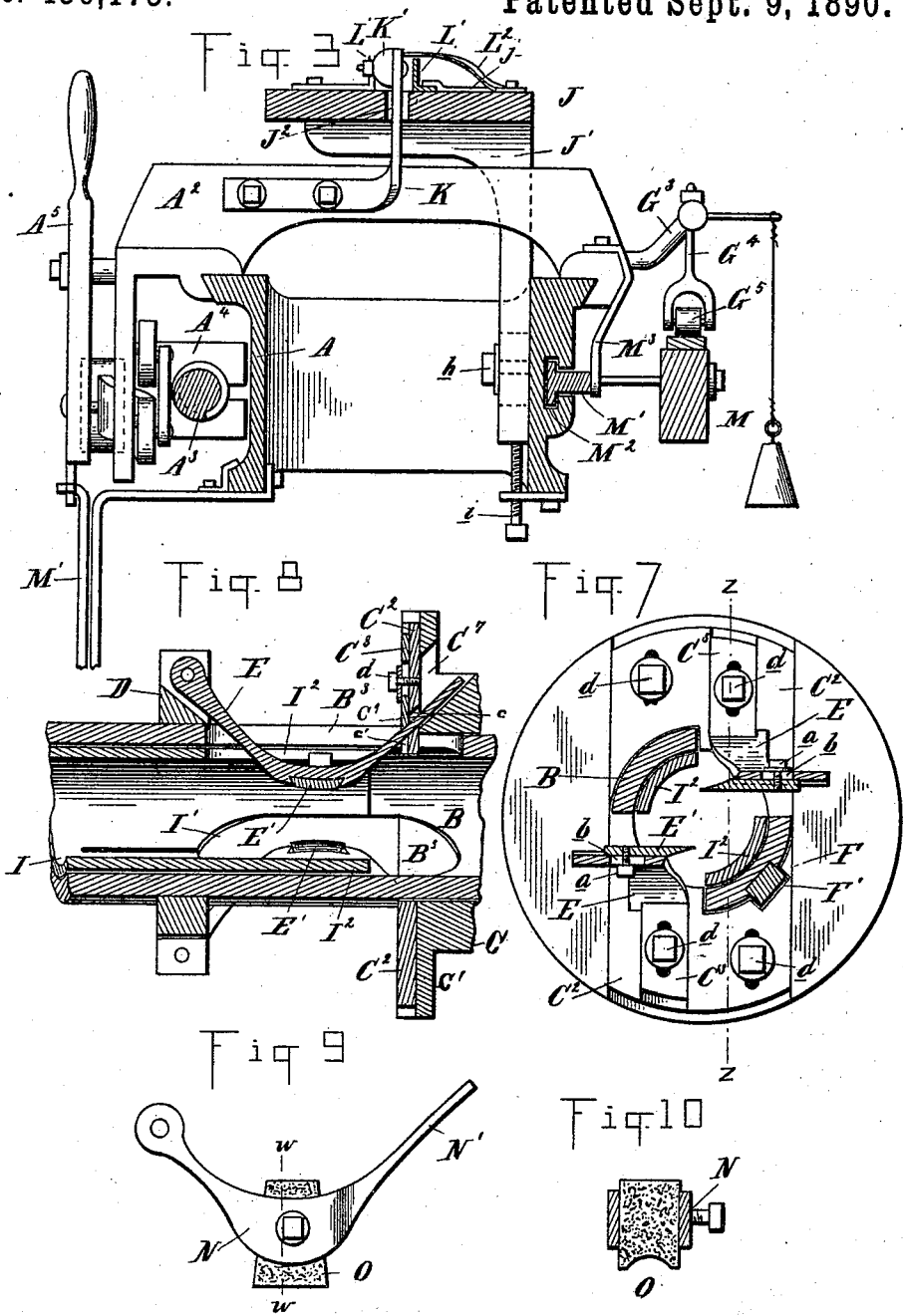

Witnesses:
P. M. Hulbert
Geo. C. Gregg

Inventor:
 John Harley.
 By *James Whittemore*
 Atty.

UNITED STATES PATENT OFFICE.

JOHN HARLEY, OF DETROIT, MICHIGAN, ASSIGNOR OF ONE-HALF TO M. J. MURPHY, OF SAME PLACE.

LATHE.

SPECIFICATION forming part of Letters Patent No. 436,175, dated September 9, 1890.

Application filed February 24, 1890. Serial No. 341,587. (No model.)

To all whom it may concern:

Be it known that I, JOHN HARLEY, a citizen of the United States, residing at Detroit, in the county of Wayne and State of Michigan, have invented certain new and useful Improvements in Lathes, of which the following is a specification, reference being had therein to the accompanying drawings.

This invention relates to new and useful improvements in hollow mandrel-lathes, and is especially designed to be used in the manufacture of chair-rounds, broom, hoe, and rake handles, &c.; and the invention consists in the peculiar arrangement and combination of parts, all as more fully hereinafter described, and shown in the accompanying drawings, in which—

Figure 1 is a plan view of my improved lathe. Fig. 2 is a front elevation thereof. Fig. 3 is a cross-section on line *x x*, Fig. 1. Fig. 4 is a rear elevation, partly in section, of the head of the lathe. Fig. 5 is a central longitudinal section through the hollow mandrel. Fig. 6 is a detached perspective view of the adjustable chuck carrying the roughing-knives. Fig. 7 is a cross-section on line *y y*, Fig. 5. Fig. 8 is a section on line *z z* in Fig. 7. Fig. 9 is a detail of the polishing-block holder. Fig. 10 is a section on line *w w*, Fig. 9. Fig. 11 is a section on line *v v*, Fig. 6.

A is the bed of the lathe, A' the legs or standards, A² the carriage, A³ the feed-screw, A⁴ the split nut, and A⁵ its controlling-lever, all being of the well-known construction of screw feed-lathe.

B is the hollow mandrel, journaled in suitable bearing B' at the head of the lathe, and carrying the pulley B², sliding sleeve C, and fixed collar B.

E represents knife-holders connected at one end to the collar D at points diametrically opposite and, curving inwardly, project at about their longitudinal centers into the aperture B³, formed in the mandrel B, and then, inclining outwardly, slidingly engage in inclined bearings C¹, formed in the sleeve C.

E' are knives adjustably secured to the holders E by means of a set-screw *a*, engaging in the slotted bearing *b*.

The sliding sleeve C is preferably constructed in the following manner:

C' is a flange or face plate having apertures C⁷, through which the rear ends of the knife-holders E pass.

C² C² and C³ C³ are plates adjustably secured by set-screws *d* to the face-plate C'. These plates have openings *cc'* therein with beveled edges, forming the incline bearings for the holders.

C⁴ is a collar loosely fitting the shank C⁵ of the sleeve, which is held from longitudinal play by the screw-threaded collar C⁶, adjustably secured on the screw-threaded end of the shank C⁵ by the set-screw *d'*.

e are ears formed on opposite sides of the collar C⁶.

f are springs secured at one end to the ears *e* and at the other to the pulley B², preferably by means of suitable screw-eyes *e'*.

F is a feather on the mandrel B, engaging in a corresponding feather-way formed in the sleeve C, adapted to rotate said sleeve with the mandrel and at the same time leave it free to move in a longitudinal direction.

G is a rock-shaft journaled in bearings G', crossing the bed of the lathe, and carrying rock-arms G², which latter are pivotally connected at their free ends to opposite sides of the collar C⁴.

G³ is a crank-arm provided with a series of screw-threaded holes, in which the arm G⁴, carrying the anti-friction roller G⁵, is adjustably secured and adapted to rest on the pattern. The crank-arm G³, rock-shaft G, and rock-arms G² together form a bell-crank lever adapted to transmit the vertical movement of the roller G⁵ produced by the movement of the pattern under it, as more fully hereinafter described.

H is an adjustable chuck, consisting of the flaring jaws H', radially adjustably secured in dovetailed grooves formed in the head H². These jaws carry the roughing-out knives *f'*, adjustably secured in slots in any suitable manner—such as by set-screws *g*—and may be adjusted in and out of the center of the mandrel by means of a right-and-left screw H³, said screw having a socket in which a suitable wrench may be engaged, as shown in Figs. 6 and 11.

g' are set-screws engaging in slots *g*², which serve to limit the movement of the jaws.

The head H^2 is centrally apertured and preferably provided with a rearwardly-extending sleeve or guide I, either formed integral therewith or having a screw-threaded engagement.

5 This sleeve, which is of a diameter to exactly fit the hollow mandrel, preferably extends through to a point opposite the finishing-knives, having a suitable cut-away portion corresponding to the apertures B^3 , through
10 which the knives pass, and is also slotted a portion of its length to admit of springing in the free ends I^2 by means of the set-screw I^3 , passing through screw-threaded apertures in the mandrel and bearing against said sleeve. The
15 sleeve I is preferably held in the mandrel B by a screw-threaded engagement.

J is a work-table secured above the bed of the lathe by brackets J' , which are vertically adjustably attached to the bed by set-screws
20 h and i . This table has a longitudinal slot in line with the center of the mandrel, in which the arm K of the carriage A^2 , carrying the pusher K' , is free to slide.

L is a guide-flange adjustably secured on
25 the table J by clamping-plates j .

L' also represents guides adjustably secured to the table, and, together with the spring L^2 and guide L, are adapted to guide the work into the mouth of the chuck H.

30 M is a pattern-carriage preferably attached to the bar M' , slidingly held in the groove M^2 on the side of the bed, and adapted to be driven by the carriage A^2 through the connecting-bracket M^3 . To this pattern-carriage
35 the pattern, which may be cut from a straight stick, is attached by screws or otherwise in any suitable manner.

In practice the parts as shown and described are intended to operate as follows:
40 The mandrel is revolved by a belt connecting the pulley B^2 by a suitable counter-shaft, and the feed-shaft is also driven by a suitable belt-connection. The operator then, taking his stand in front of the machine, places a
45 square stick against the guide L' on the table J, which has previously been so adjusted as to bring the work in line with the center of the mandrel. The lever A^5 is then dropped either by hand or by foot-lever M^4 , which en-
50 gages the split nut A^4 with the feed-screw A^3 and moves the carriage forward, thereby forcing the stick by means of the pusher K into the mouth of the chuck H, where the roughing-out knives reduce it to a size which will
55 readily enter the mandrel, the guides LL' and spring L^2 serving to hold it firmly while being operated upon by the knives. At the same time the pattern-carriage M, moving
60 along with the carriage, brings the pattern underneath the roll G^4 , alternately raising and lowering it, and thereby producing a rocking motion of the bell-crank, formed of the crank
65 G^3 , rock-shaft G, and rock-arms G^2 , and a corresponding forward or backward movement of the sleeve C, which in turn forces the knife-

holder, thus shaping the stick to the form desired.

It will be seen by examining Fig. 8 of the drawings that the knife-holder in traveling
70 in or out from the center of the mandrel will always hold the knives tangentially to the work, thereby making a smoother cut and allowing a greater amplitude of movement than if otherwise arranged.
75

If it is desired to polish the work while still in the lathe, a holder N may be substituted for one of the knife-holders E, which, as shown in Figs. 9 and 10, is adapted to hold
80 a block of emery O. In the operation of the device this polishing-block is held in contact with the finished work slightly in advance of the finishing-knives.

The arm N' of the holder N is preferably made light enough to be slightly elastic,
85 thereby readily adjusting itself to the work.

As soon as one stick is fed into the mandrel the stop k of the lever A^5 will strike against the fixed stop l , attached to the bed, thereby
90 tripping the lever and releasing the split nut from its engagement with the feed-screw, thus allowing the carriage A to be drawn back to its initial position by the rope P and weight Q.

A suitable stop R, made of rubber or other elastic material, serves as a bumper for the
95 carriage to strike when withdrawn.

The finished stick passes out of the mandrel through the dead-rolls S.

Whenever it is desired to cut a stick of smaller diameter than the bore of the mandrel
100 I am enabled to do so by simply adjusting the jaws of the chuck H in nearer to the center of the mandrel, and to prevent the chattering which would occur if the stick when operated upon by the finishing-knives were
105 smaller than the sleeve-guide I the latter may also be adjusted by means of the set-screw I^3 , which presses the jaws I^2 into contact with the work, thus holding it securely from lateral displacement.
110

It will be seen that all the parts of my device liable to wear are provided with suitable adjustments—as, for instance, in the sleeve C, whenever the collar C^4 wears away sufficiently to allow of lateral play, by loosening
115 the set-screw d' the collar C^6 may be turned slightly, thereby taking up all lost motion. The plates C^2 and C^3 , forming bearings for the knife-holders, may also be adjusted when necessary either to compensate for wear or
120 to bring the knives nearer to or farther from the center of the mandrel—an operation which would slightly vary the form of the finished work.

What I claim as my invention is—
125

1. In a lathe, the combination, with the hollow mandrel, of a chuck consisting of jaws having elongated openings therein, bolts passing through the openings, a head having dovetail grooves in its face in which the jaws are
130 placed, and a right-and-left screw for moving the jaws, substantially as described.

2. In a lathe, the combination, with the hollow mandrel, of a tubular guide I, constructed with adjustable spring clamping-jaws and arranged within said mandrel, and binding-screws I³, impinging against the spring-jaws, substantially as described.

3. In a lathe, the combination, with the hollow mandrel, of the guide I, consisting of the spring clamping-jaws I², the set-screws I³, for adjusting same, the jaws having the cut-away portion I¹, and the finishing-knives, substantially as described.

4. In a lathe, the combination, with a hollow mandrel having openings therein, of swinging holders having inclined outer ends pivoted on the mandrel opposite said openings, knives in said holders, and a sliding sleeve engaging directly with the inclined end of the holders to move the same radially, substantially as described.

5. In a lathe, the combination, with the mandrel having openings therein, of the knives pivotally secured thereto opposite the openings, a pattern, a pattern-carriage carrying said pattern, the feed-screw for actuating said carriage, and the arm K, substantially as described.

6. In a lathe, the combination, with the hollow mandrel, of the knife-holders pivoted opposite apertures therein and carrying the

knives, the sliding sleeve C, the incline bearings C² C³, and the springs f, substantially as described.

7. In a lathe, the combination of the hollow mandrel, the knife-holders E, pivoted opposite apertures therein at one end and having an arm extending in guide-bearing between the plates C² C³, the sliding sleeve, the collar C⁴, the rock-shaft G, the rock-arm G², the crank-arm G⁴, the pattern-carriage, and the roll G⁵, adapted to bear upon the pattern thereon, substantially as described.

8. In a lathe, the combination, with a hollow mandrel, of a swinging holder pivoted to the same, a polishing-block on the holder, and a sliding sleeve engaging the holder to move the same, substantially as described.

9. In a lathe, the combination, with a mandrel, of swinging knives pivoted at one end on the mandrel, their opposite ends being inclined outwardly, and means for engaging the inclined ends of the knives for radially moving the same, substantially as described.

In testimony whereof I affix my signature, in presence of two witnesses, this 19th day of December, 1889.

JOHN HARLEY.

Witnesses:

M. B. O'DOHERTY,
P. M. HULBERT.